

WALL MOUNT VANITY

INSTALLATION INSTRUCTIONS

TOOLS/MATERIALS NEEDED:

Tape Measure

3" Wood Screws

Utility Knife

Electric Screwdriver

Circular Saw

Construction Adhesive

Hammer

Pencil

Wood Chisel

mounting height

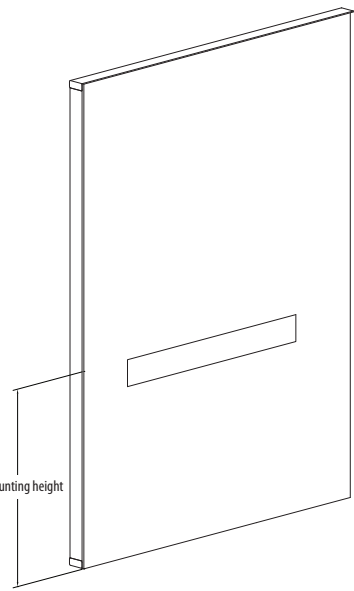

Score a line across the wall at the desired mounting height. Score another line 6 inches below the first line.

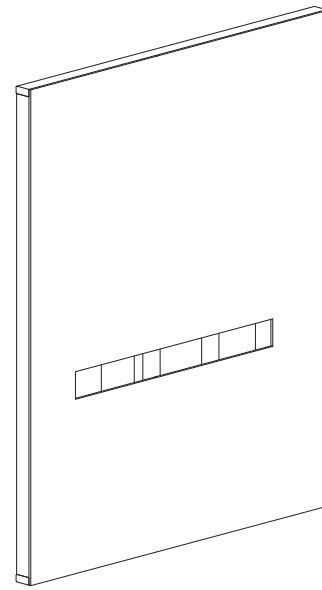

Using a utility knife, cut through the score lines and remove the 6" wide strip of drywall. The length of the opening should be equal to the length of the cabinets, PLUS the distance to the next wall stud in each direction.

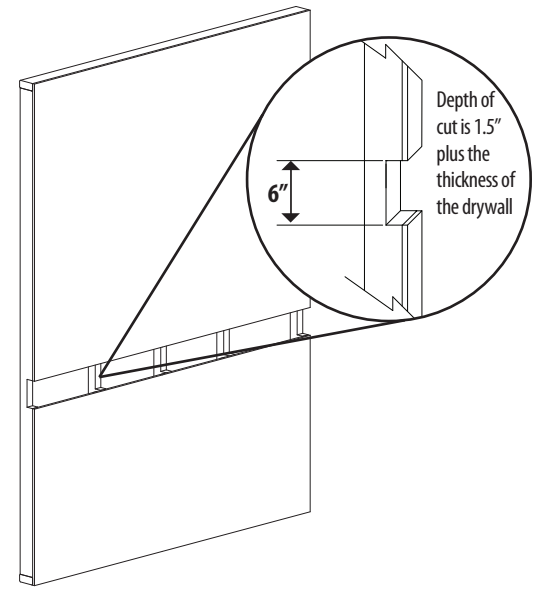

Place your 2 x 6 in the opening and score a line across the face of the studs. Use a circular saw to make two cuts to the appropriate depth (1.5" deep on the stud, PLUS the thickness of the drywall); one on the pencil line and one on the bottom edge of drywall.

Make 3-4 additional cuts in the area between these cuts, and remove by striking with a hammer. The notch should be cleaned up with a chisel as needed.

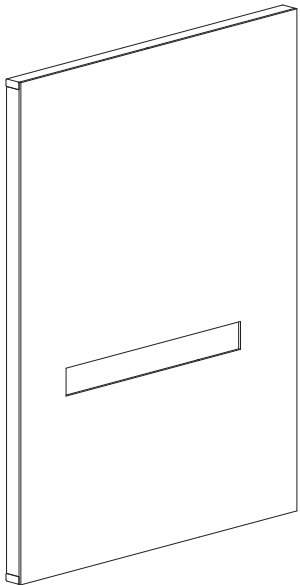

Place 2x6 in the notched area and secure with (2) 3" screws and construction adhesive on each stud. The face of the 2x6 should be flush with the surface of the studs.

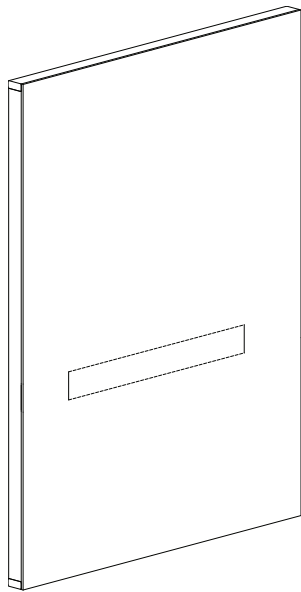

Replace strip of drywall.

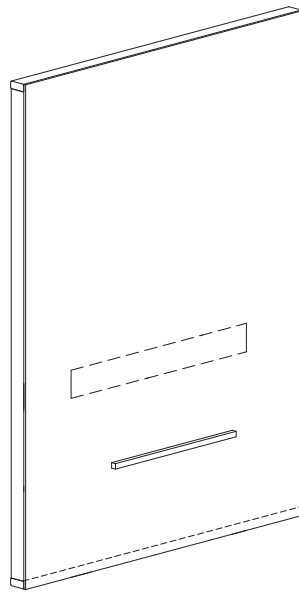

Cut ledge strip 2 inches less than run length. Center on run and fasten to studs using 3" screws.

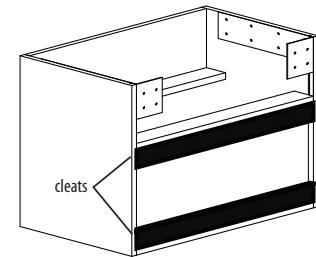
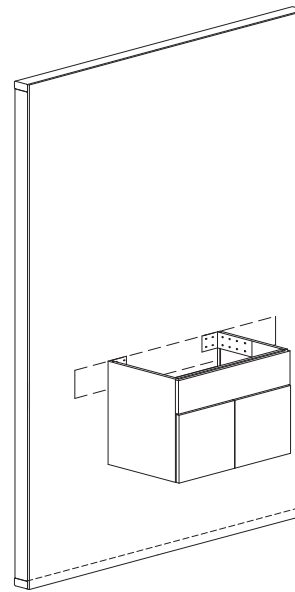

Each vanity has 2 cleats. Both cleats need to be screwed to a stud every time they intersect one.

Rest cabinet on ledge and secure hanging brackets to the 2x6. If the vanity butts up to a side wall, fasten the vanity to the side wall as well, securing with a 3" screw into a stud. ****Any cabinet without a hanging bracket MUST BE SECURED to an adjacent cabinet or wall. May be secured with wall screws into a stud.**